

# Fitting guide

Spraydown flaps unique construction means the fixing arrangements are different to other mat-type flaps. Follow the guidelines below to ensure the flaps work as designed and to their optimum performance.

spraydown

## Orientation on the vehicle

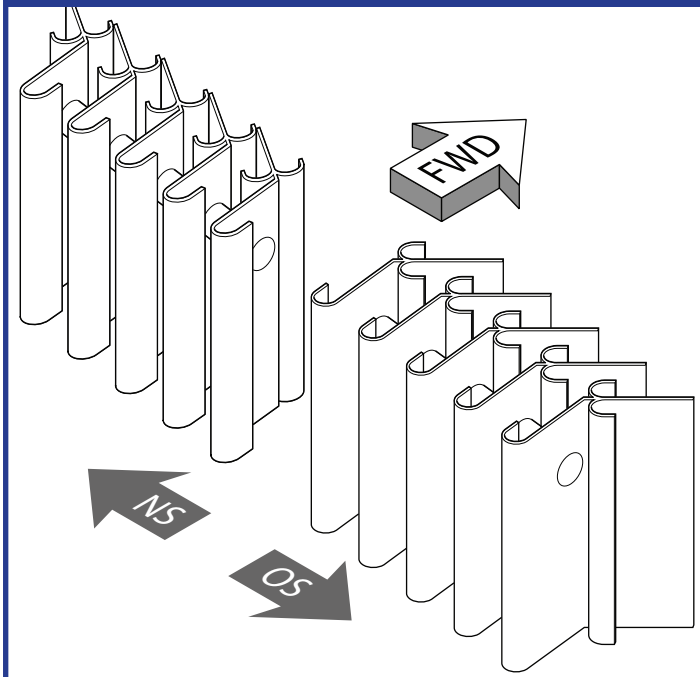

## Installing the Brackets

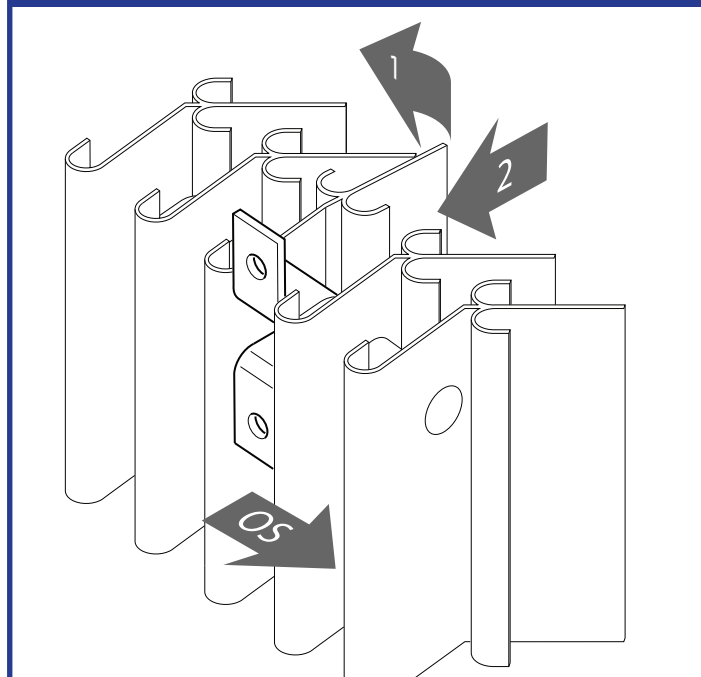

## Fitting the Flaps to Mudguards

The flaps should be fixed to the mudguards using bolts, penny washers and locknuts.

- At least three fittings should be used as per the diagram.
- Do not position the flap further into the mudguard than is necessary for fixing.
- Fit at the maximum distance from the ground (200mm or 300mm for Ro-Ro Ferries).

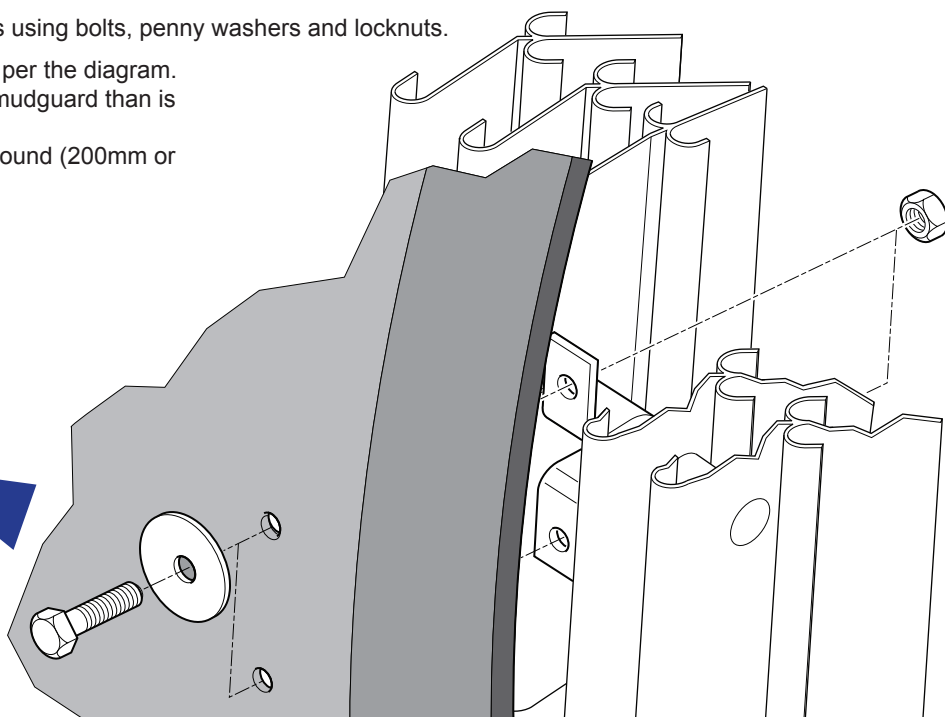
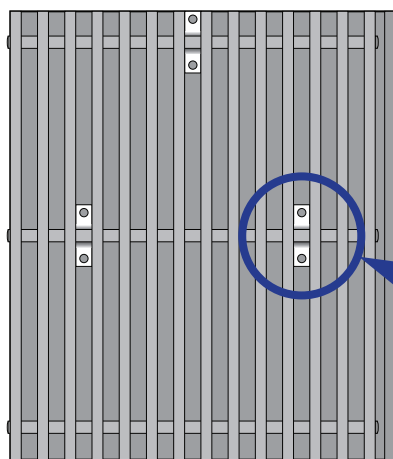

## When fitting the flap:

- Adhere to the normal safety rules and regulations when working on the vehicle
- Fitting the flaps is easier if the mudguards are off the vehicle.
- Position the new flaps in accordance with vehicle regulations and drill the mudguards.
- Ensure the mudguards are in good condition.
- Use penny washers with locknuts or standard nuts with thread lock.

## Other Applications:

- In other applications, use two fittings on the top tie rod and an anti sail bar or additional fittings on lower tie rods where appropriate

We would recommend that the product is fitted as a suppression device in accordance to the British Standard BS AU 200-1a. If you require any further information or advice please visit our website [www.spraydown.com](http://www.spraydown.com).